

SOLANA[®]

Serenity made simple[™]

**Watkins
Manufacturing
Corporation**



PRE-DELIVERY INSTRUCTIONS

Please take the time to read this booklet carefully, as it will provide you with the information you will need to ensure the safe, secure, and timely installation of your new spa. The following sections are guidelines on how to prepare for delivery and set-up of your new spa. Specifically covered are site selection, delivery access, ground preparation, and electrical requirements.

Remember to carefully read the Owner's Manual that accompanies your spa, and to complete the warranty card within 10 days of delivery. These items, along with other valuable information, will be found in the Owner's Package that has been placed behind the front access panel of your spa, where you will also find its serial number.

Watkins Manufacturing Corporation reserves the right to change features, specifications and design without notification and without incurring any obligation.

SOLANA®

DATE PURCHASED: _____

DATE INSTALLED: _____

DEALER: _____

ADDRESS: _____

TELEPHONE: _____

In most cities and counties, permits will be required for the installation of electrical circuits or the construction of exterior surfaces (decks and gazebos). In addition, some communities have adopted residential barrier codes which may require fencing and/or self-closing gates on the property to prevent unsupervised access to a pool (or spa) by children under 5 years of age. Your Solana spa is equipped with a locking cover and is usually exempt from most barrier requirements. As a general practice, your local Building Department will inform you of any applicable barrier requirements at the time a permit is obtained for the installation of an electrical circuit. Your Solana dealer can provide information about which permits may be required.

SITE SELECTION AND PREPARATION

IMPORTANT: Site selection and preparation are your responsibility. Carefully read these instructions and consult your authorized Solana® dealer if you have any questions.

You probably have selected a location for your new spa, whether it's indoors or outdoors, on a patio or on a deck. Just make sure you check the following:

- Always place your spa on a structurally sound, level surface. A filled spa can weigh a great deal. Make certain that the location you choose can support the weight of your filled spa.*
- Don't forget to level your spa before filling it. (See Spa Leveling Instructions included in Owner's Manual.)*
- Locate your equipment compartment (located behind the front access panel), which houses all of the electrical components, in a place where water will drain away from it. Allowing water into the equipment compartment can damage the electronics, or may result in tripping your house's circuit breaker.*
- Leave yourself easy access to the circuit breakers in the sub-panel (converted 30 amp models), or to the interrupter switch on the end of the power cord (standard models).*
- Never let water get into the sub-panel (converted 30 or 50 amp), into the interrupter switch (standard models), or into the electrical outlet that your spa is plugged into.*
- Leave access to the equipment compartment (front access panel for TX model) for periodic spa care and maintenance.*

INDOOR INSTALLATION

Be aware of some special requirements for indoor spas. Water will accumulate around the spa, so flooring materials must provide a slip-resistant surface when wet. Proper drainage is essential to prevent a build-up of water around the spa. It is highly recommended that a carpet remnant, carpet pad or rubber mat be cut to the footprint of the spa, and that the spa be placed directly on it. This minimizes noise associated with spa operation. When building a new room for the spa, it is recommended that a floor drain be installed. The humidity will naturally increase when water is added to the spa. Water may get into woodwork and produce dryrot, mildew, or other problems. Check for airborne moisture's effects on exposed wood, paper, etc. in the room. To minimize these effects, it is best to provide plenty of ventilation from the spa area. An architect can help to determine if more ventilation must be added.

Your Solana spa dealer can help you with local information such as zoning regulations and building codes.

CAUTION: *Do not install the spa on a heated floor surface. This will damage the bottom of the spa.*

DECK INSTALLATION

To be certain your deck can support your spa, you must know the deck's maximum load capacity. Consult a qualified building contractor or structural engineer before you place the spa on an elevated deck or indoors. To find the weight of your spa, its contents and occupants, refer to the spa specifications. This weight per square foot must not exceed the structure's rated capacity, or serious structural damage could result.

OUTDOOR INSTALLATION

No matter where you install your new spa, it's important that you have a solid foundation to support it. Structural damage to the spa resulting from incorrect installation or placement on an inadequate foundation is not covered under the spa's limited warranty.

If you install the spa outdoors, a reinforced concrete pad at least four inches thick is recommended. The reinforcing rod or mesh in the pad should be attached to a bond wire (see your Owner's Manual).

If you place the spa on the ground, even temporarily, place stepping stones under the leveling areas (see Spa Leveling Instructions in your Owner's Manual). The stones should be at least two inches thick and twelve inches square. Even with stones in place, the spa will inevitably settle and become unlevel. A spa surrounded by dirt or grass will soon be filled with dirt or grass from users' feet; therefore, it is important to get the spa onto a solid foundation as soon as possible.

DELIVERY ACCESS

First, locate the dimensions of your spa on the following page. The dimensions shown are the measurements of the spa in the vertical position, laid on its side.

Next, contact your dealer to find the height and width added by the delivery cart which the dealer will use to deliver your new spa. Use the height of the cart plus the dimension shown as H to determine the vertical clearance required to pass the spa and cart. Use the width of the cart, or dimension W, whichever is greater, to determine the maximum width of clearance necessary.

NOTE: It may be necessary to allow for additional over-head clearance if the spa will be rolled up or down an incline or moved up or down a short flight of stairs.

Use the information on the following page to determine the requirements for access to your desired location.

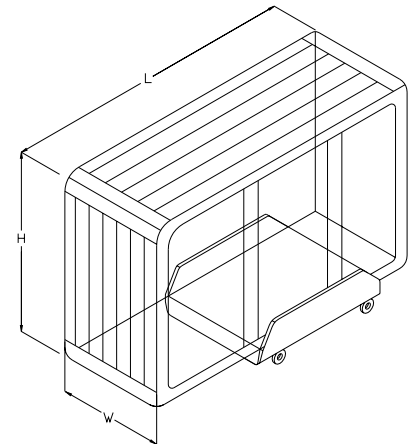

It may be necessary to remove a gate, part of a fence, or other movable obstructions in order to roll the spa to its installation site. About ten percent of the time, a crane is the only way to install the spa by lifting it to its final destination.

If the spa has to be taken off of the cart to go over a wall (either because the entry area is too narrow, the eaves are too low, the corner is too tight, or the stairway is too steep), a crane may be required. Don't be alarmed!

The crane has a truck-mounted boom which can fit right in your driveway. It is run by a licensed and insured operator. For a charge, the crane operator will lift your spa over walls, buildings, or any other obstruction and place it as close to the installation site as possible. The Solana® spa delivery personnel will supervise the crane delivery and complete the spa installation. Crane delivery typically takes an average of 30 minutes to complete.

NOTE: If your spa delivery requires the use of a crane, you may be required to pay for its services at the completion of the delivery.

GROUND PREPARATION

Your Solana spa has been engineered to perform on all kinds of common yard surfaces. While a concrete slab is best for long-term use, other foundations are acceptable as long as a level base is prepared prior to delivery. Three foundation base pictures, shown on the next page, represent examples of alternatives to a concrete slab for spas installed without gazebos or other accessories.

Model	Width W	Length L	Height H
TX	29"	67" Triangular	67" Triangular
SX	33"	72" Square	72" Square

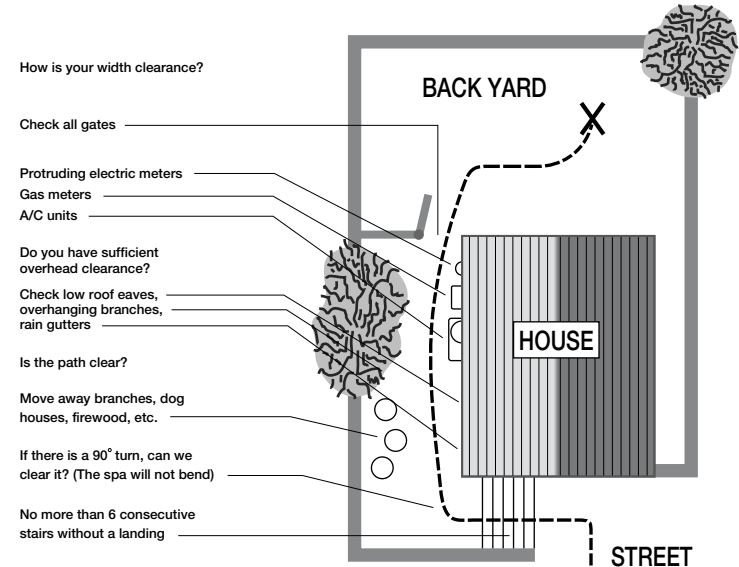

INSTALLATION NOTES:

- If stepping stones or railroad ties are selected for the spa foundation, they should be placed at the designated leveling areas of your spa to maintain even distribution of the spa weight.
- It is important to note that soft surfaces, even when stepping stones are used to distribute the weight of the spa as evenly as possible, will still have a tendency to settle unevenly, resulting in an unlevel spa.
- Remember, placing the spa on grass or dirt may increase the amount of debris which is inadvertently brought into the spa water on the user's feet.

If you are purchasing a deck package or a gazebo with your spa, a solid foundation becomes mandatory. Placing them on any surface other than a single level pad could create problems with their installation. Pictured at right are a few of the recommended surfaces.

As a homeowner, it is your responsibility to provide a suitable, level foundation for your spa. Keep in mind that most delivery crews are not equipped to level and prepare spa sites.

If you are interested in having a concrete slab, brick surface, or wood deck installed, your Solana® dealer should be able to suggest a qualified, licensed contractor.

NOTE: In order for the spa to operate properly and for the internal plumbing to drain completely, you must ensure that the spa is leveled after it has been installed. The diagram on the following page indicates the recommended shimming points on your spa's base support system. Your Solana spa delivery crew can help you perform the procedure.

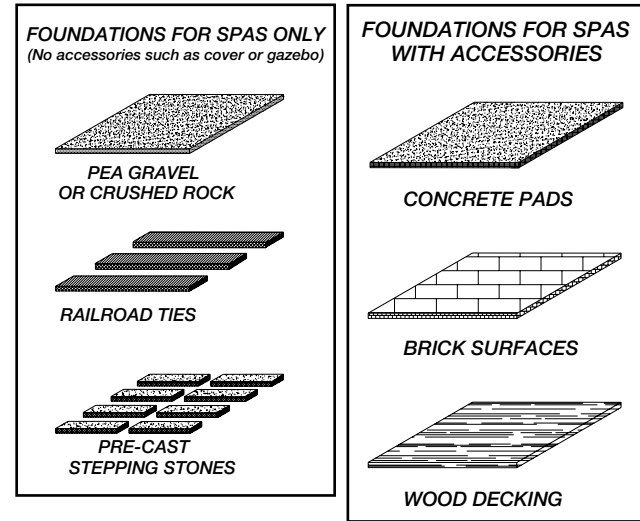

SOLANA[®] TX

DIMENSIONS

All dimensions are approximate; measure your spa before making critical design or pathway decisions.

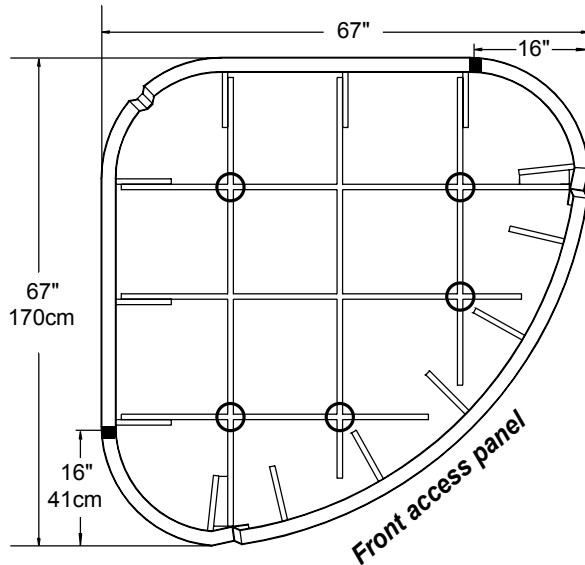

UPSIDE DOWN VIEW OF SPA WITHOUT BASE PAN

5 possible shimming points circled
(dimple location in base pan)

■ = Power cord exits

SOLANA

SPECIFICATIONS

HORIZONTAL DIMENSIONS:..... 67"x 67" (170 cm x 170 cm)

HEIGHT (without cover): 29" (74 cm)

EFFECTIVE FILTER AREA:..... 30 sq. ft. (2.7 sq. meters)

HEATER:..... 1000 watts (1.0 kW) @ 115V, 4000 watts @230V

WATER (capacity): 130 gallons (492 liters)

WEIGHT: 324 lbs. dry (147 kg), 1,714 lbs. filled (777 kg)
(Includes weight of water and 2 adults @ 175 lbs. ea.)

DEAD WEIGHT (filled):..... 70 lbs. per sq. ft., 340 kg per sq. meter

ELECTRICAL REQUIREMENTS: 115 volt 15 amp grounded circuit (standard)

115 volt 30 amp grounded circuit (optional)*

230 volt 50 amp grounded circuit (optional)*

* requires a 30 or 50 amp sub-panel

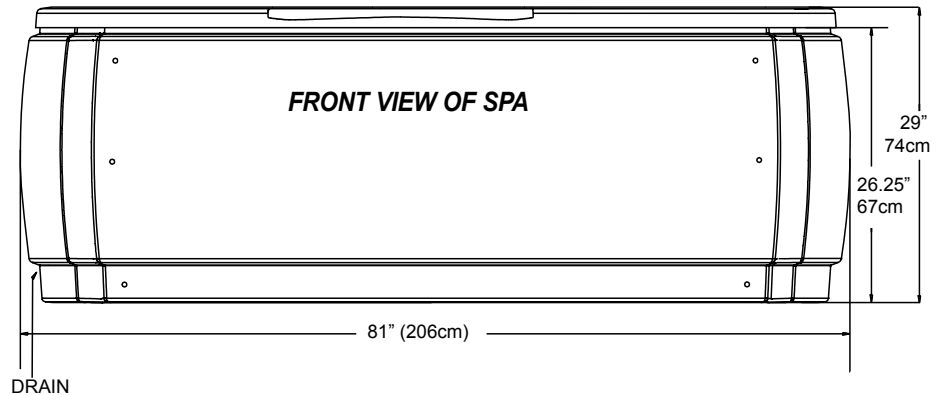

FRONT VIEW OF SPA



ELECTRICAL INFORMATION

To ensure you will have an opportunity to use your spa soon after delivery, it is very important that the required electrical service has been installed. Unless otherwise stipulated by your dealer, **THIS IS YOUR RESPONSIBILITY.**

IMPORTANT: All electrical circuits must be installed by a qualified, licensed electrician.

Your Solana® spa has been carefully designed to give you maximum safety against electrical shock. Connecting the spa to an improperly wired circuit will negate many of the spa's safety features. Please read and follow the electrical installation requirements and instructions for your specific spa model completely!

There are four electrical configurations associated with Solana spas. Each spa comes standard as a 115 volt 15 amp or 20 amp, cord-connected electrical configuration, which is designated as an "either/or" hydromassage system. This means that the heater will not activate simultaneously with the high speed mode of the jet pump. If you use your spa for extremely long periods of time with the high speed jet pump operating, you may experience a slight drop in water temperature. This happens because the heater will not heat while the pump is running on high. To allow the heater to operate at the same time as the high speed jet pump, the spa may be converted (by an authorized technician) to a 115 volt 30 amp hard-wired configuration. The 30 amp configuration provides enough electrical current to allow the heater and the high speed jet pump to operate simultaneously. The 50 amp configuration operates the same as the 30 amp as well as it increases the heater watts from 1Kw to 4Kw allowing the water to heat quicker. Conversions require electrical modification within the control box (contact an authorized Solana Service Technician) and the installation of an electrical subpanel (available from your Solana Dealer). A licensed electrician must install the subpanel.

ELECTRICAL REQUIREMENTS

The spa must be connected to a 115 volt, 15 or 20 amp (30 or 50 amp for converted models) grounded circuit. The equipment pack requires a MINIMUM of 110 volts under load. A dedicated circuit is required; the term "dedicated" means the electrical circuit is not being used for any other high-load electrical items (patio lights, appliances, garage circuits, etc.). If the spa is connected to a non-dedicated circuit, overloading will result in "nuisance tripping" of the internal fuses or of the breaker switch at the house electrical breaker panel.

The circuit must be properly wired; that is, it must have the following:

- Standard (cord-connected) 115 volt 15 amp (TX Spa only) - A minimum 15 amp GFCI circuit breaker in the house breaker panel, #14-AWG or larger wire (including the ground wire) and the correct polarity throughout the circuit.
- Standard (cord-connected) 115 volt 20 amp (SX Spa only) - A minimum 20 amp GFCI circuit breaker

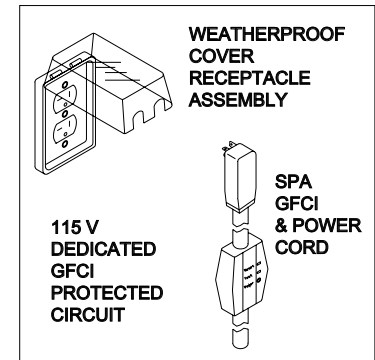

in the house panel, #12-AWG or larger wire (including the ground wire) and the correct polarity throughout the circuit.

- *Converted (hard-wired) 115 volt 30 amp – A minimum 30 amp circuit breaker in the house breaker panel, #10-AWG or larger wire (including the ground wire), a subpanel with an appropriate GFCI breaker, and the correct polarity throughout the circuit.*
- *Converted (hard-wired) 230 volt 50 amp – A minimum 50 amp circuit breaker in the house breaker panel, #8-AWG or larger wire (including the ground wire), a subpanel with an appropriate GFCI breaker, and the correct polarity throughout the circuit.*

A pressure wire connector is provided on the exterior surface of the spa’s electrical control box, located inside the equipment compartment. This is to permit the connection of a bonding ground wire between this point and any metal equipment, enclosures, pipe or conduit within five feet of the spa (if needed to comply with local building code requirements). The bonding wire must be at least a #8 AWG solid copper wire.

NEVER CONNECT THE SPA TO AN EXTENSION CORD!

Each Solana® spa comes equipped with approximately 15 feet of usable power cord (this is the maximum length allowed by regulatory standards and the National Electric Code). The power cord is stored for shipping inside the equipment compartment. To remove the power cord, open the equipment compartment and locate the cord. Carefully pull the cord out of the equipment compartment to the desired length.

If you choose to convert your spa to 115 volt 30 or 50 amp operation (contact an authorized Solana spa Service Technician to perform the conversion), a licensed electrician must install the subpanel (available from your Solana dealer).

STANDARD, CORD-CONNECTED 115 VOLT 15 OR 20 AMP CONFIGURATION

For your safety, when your electrician is installing the electrical outlet, it should be no closer than five (5) feet and no farther than ten (10) feet from the spa. (Reference National Electric Code 680-6a(1) and 680-41a.)

One GFCI is used in the cord-connected 15 or 20 amp configuration. The GFCI module is located at the end of the power cord. To test the GFCI, simply press the TEST button. The GFCI should trip to the “off” position, disconnecting power to the spa. To reset the GFCI, press the RESET button. The GFCI should reset, and power should be restored to the spa. If the GFCI does not function in this way, unplug the cord and contact an authorized Solana Spa Service Technician.

NOTE: Consult your local code authority to determine if an electrical outlet with a cover is required for your installation. If it is, a suitable outlet cover may be purchased from your Authorized Solana dealer. Ask for Part #71591.

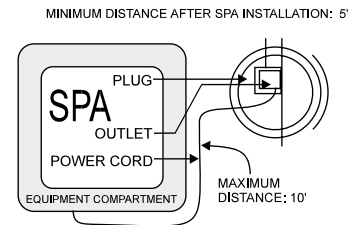

CONVERTED 115 VOLT 30 AMP OR 230 VOLT 50 AMP CONFIGURATION

30 or 50 Amp Subpanel Wiring Instructions:

NOTE: The subpanel must be placed within 100 feet of the main electrical service panel, and between 5 and 50 feet away from the spa. Refer to the wiring diagram below for 30 amp and on the next page for 50 amp. A 115 volt 30 or 230 volt 50 amp subpanel may be purchased from your local Solana® dealer. See next page for 30 amp jumper (JP) configuration.

A licensed electrician should install three-wire electrical service (one line voltage, one neutral, one ground) from the main electrical service panel; to the subpanel.

The grounding conductor must be the same gauge or greater than the line conductor. Your electrician should mount the subpanel in the vicinity of the spa but it should not be closer than five (5) feet from the spa water edge (NEC 680-6c).

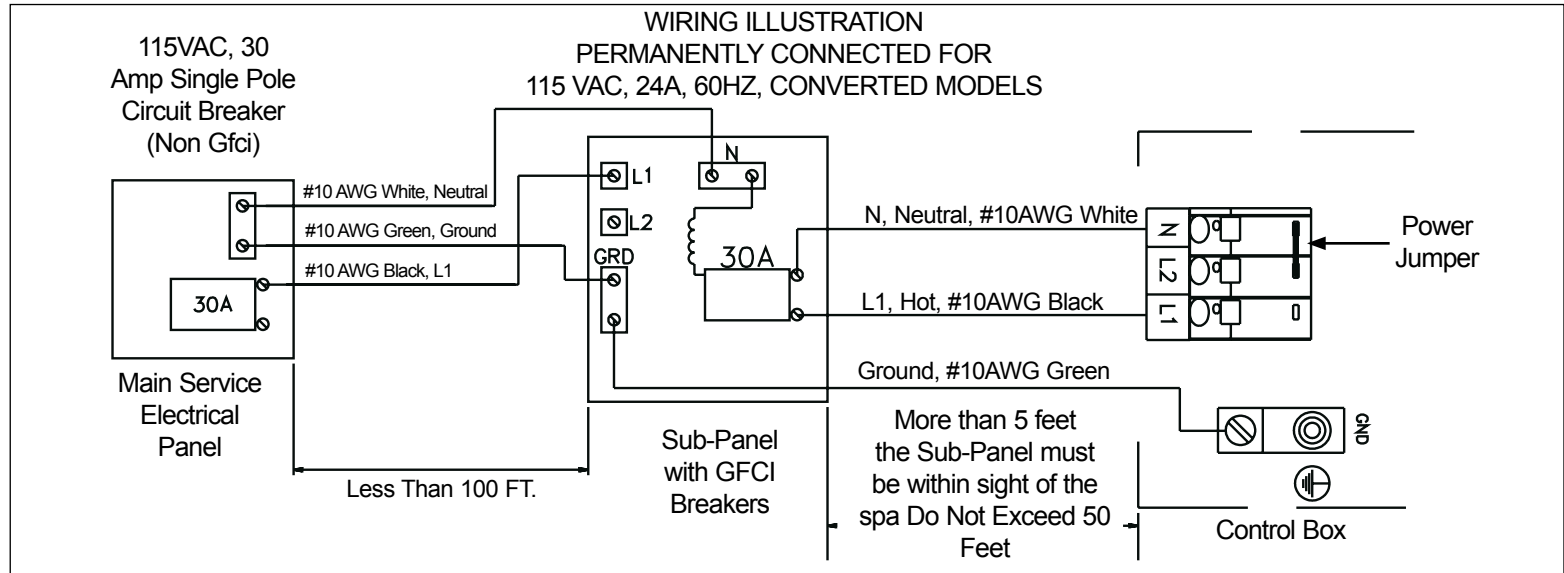

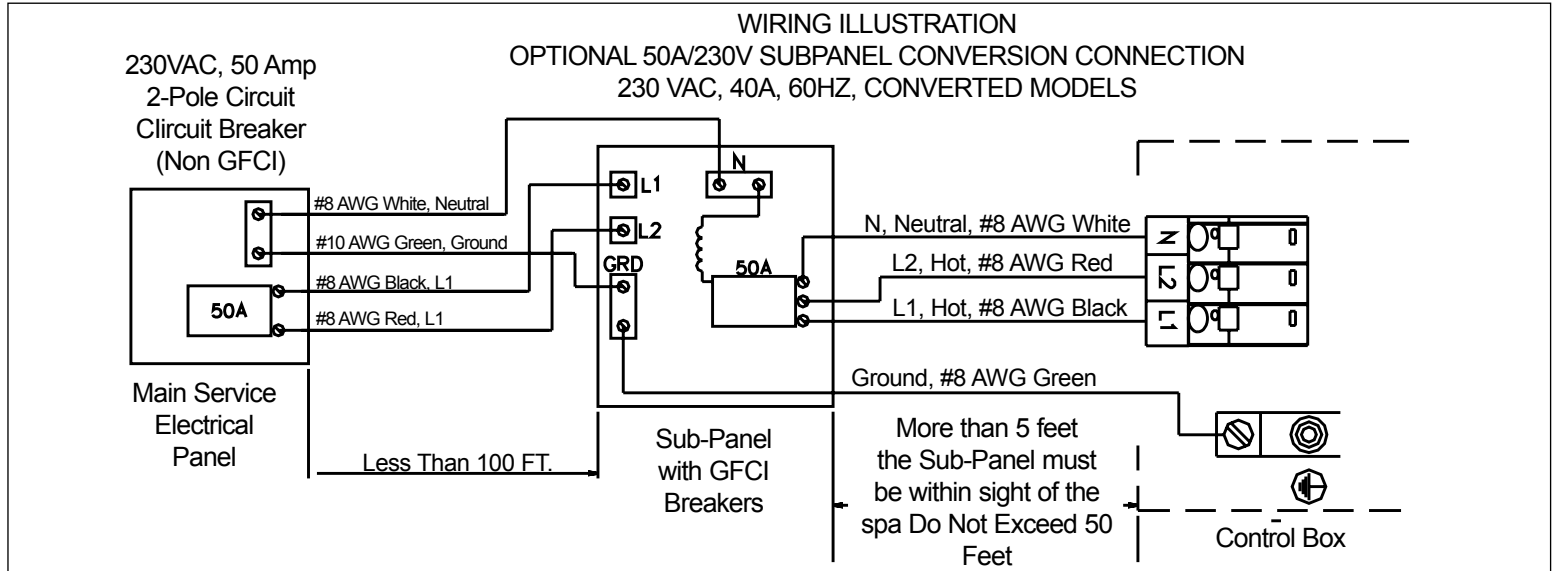

Power Jumper Position

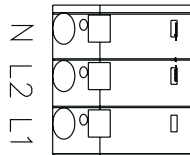

See Wiring
 Illustration

**230 VAC Wiring
 (50A Converted)**

2 Position Power Jumper
 must be removed on the
 Terminal Block to operate
 230 VAC Spa Models

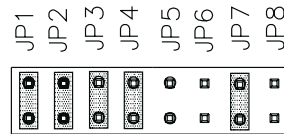

When Converting to 30 Amp or
 50 Amp, Install Jumper on JP1

NOTE:

- Jumpers are located in top right corner of Control Box labeled P4 "Config Jumpers"
- To Change from fahrenheit to celsius remove jumper on JP2.
- Verify Red Internal Power Jumper is connected at P40 (B) to P24 (B).

INSTALLATION NOTE: After the spa has been installed by the dealer's delivery crew, your electrician can connect the conduit from the subpanel to the spa's Control Box and then complete the wiring connections in the control box.

NOTE: Complete step-by-step Installation and Wiring Instructions for all 30 and 50 amp Solana® Models are included in the Owner's Manual and with each subpanel obtained from your dealer.

WARNING: Removing or bypassing the GFCI circuit breakers in the subpanel at any time will result in an unsafe spa and will void the warranty.

Wire Specification

NOTE: Long Electrical runs may require a larger gauge feed wire than stated. We recommend that a maximum voltage drop of 3% be used when calculating the larger wire size.

ADDITIONAL PRODUCTS AVAILABLE FROM YOUR SOLANA® SPA DEALER

- EverFresh® water care system
- FreshWater® water care products
- Replacement filter cartridges
- Vinyl covers
- Spa vacuums
- Pillows
- Vanishing Act™ calcium remover
- Clean Screen™ pre-filter
- HydroPulse® face plate
- Spa upgrade jet kits

SERVICES AVAILABLE FROM YOUR SOLANA® SPA DEALER

<i>SERVICE</i>	<i>COST</i>
<i>Pre-Delivery site inspection</i>	_____
<i>Deliver spa to installation site</i>	_____
<i>Unwrap spa and haul away packaging material</i>	_____
<i>Set up & level spa</i>	_____
<i>Fill the spa with water</i>	_____
<i>Connect the spa to its power source (115 volt)</i>	_____
<i>Explain and test the spa's operation</i>	
• Jet system	• Comfort Control® system
• Set temperature control	• Control panel functions
<i>Explain the safety features</i>	
• GFCI • Heater high limit • Heater thermal cut-off	
<i>General spa operation & maintenance orientation</i>	_____
<i>Water quality and maintenance orientation</i>	_____
<i>Adjust the water's TA, CH and pH</i>	_____
<i>Sanitize the water</i>	_____
<i>Inspect the spa cover, place on spa</i>	_____
<i>Review winterizing instructions</i>	_____
<i>Review Owner's Manual & Warranty Card</i>	_____
<i>Follow-up call</i>	_____
<i>In-store spa water analysis</i>	_____
TOTAL COST	_____

Watkins
The Home Relaxation Specialists

WATKINS MANUFACTURING CORPORATION

1280 Park Center Drive

Vista, California 92081

(800) 999-4688 extension 8432

©2010 Watkins Manufacturing Corporation. Hot Spring, Solana, Vanishing Act, Clean Screen, Cover Shield, Freshwater, EverFresh, Comfort Control, Serenity Made Simple and The Home Relaxation Specialists are trademarks of Watkins Manufacturing Corporation.